

TOP LIFTER

Tailgates By THIEMAN

TT-12

OWNERS MANUAL/PARTS LIST

SHOWN WITH OPTIONAL 2 PC. ALUMINUM PLATFORM

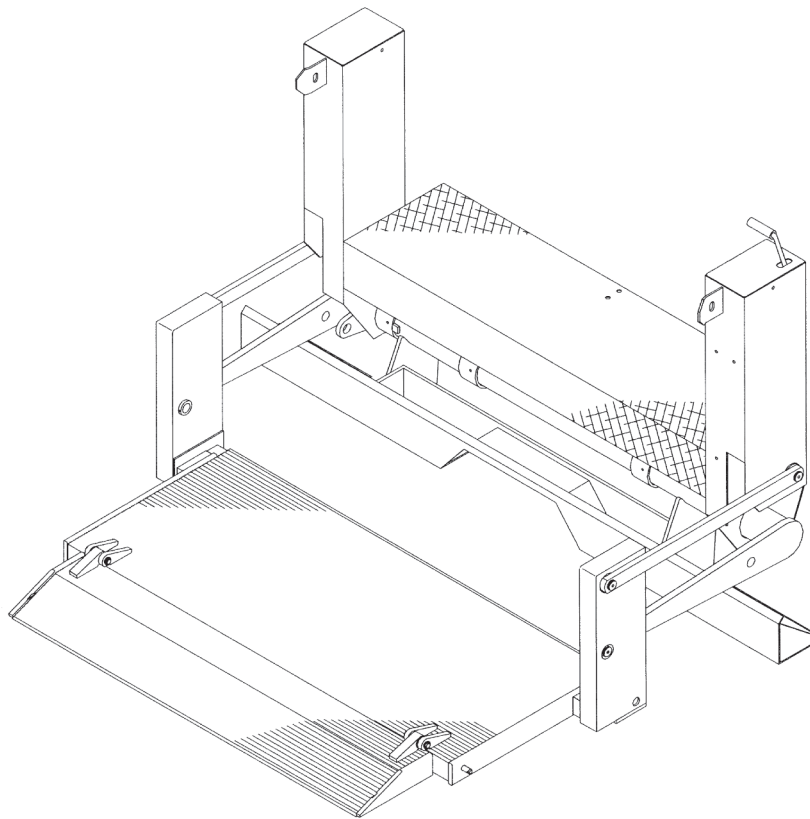

IMPORTANT! KEEP IN VEHICLE!

PLEASE READ AND UNDERSTAND THE CONTENTS OF THIS
MANUAL BEFORE OPERATING THE EQUIPMENT.

THIEMAN
TAILGATES, INC.

600 East Wayne Street
Celina, Ohio 45822

Phone: 419-586-7727 Fax: 419-586-9724

NTEA
THE ASSOCIATION FOR THE WORK TRUCK INDUSTRY
MEMBER

TABLE OF CONTENTS

WARNINGS.....	3
OPERATING INSTRUCTIONS	5
MAINTENANCE GUIDE.....	5
SEMI-ANNUAL INSPECTION.....	6
INSPECTION AND LOCATION OF DECALS	7
ELECTRICAL PICTORIALS	8
PARTS ORDERING PROCEDURE	8
PUSHBUTTON CONTROL GRAVITY DOWN POWER UNIT	9
MANUAL CONTROL GRAVITY DOWN POWER UNIT	10
TRUNNION AND LIFT ASSEMBLY.....	11 & 12
TROUBLESHOOTING GUIDE.....	13-15

FOR YOUR RECORDS

Model No. _____ Date Purchased _____
Serial No. _____

Your Thieman Tailgate is constructed of top quality material and is warranted to be free from defects in material and workmanship under normal use. With routine maintenance and proper operation this liftgate will provide long lasting service and dependability.

THERMAL DATA: To avoid overheating the motor do not operate this unit for more than 20 cycles/10 minutes with the maximum load. The motor then must be allowed to completely cool down to ambient temperatures before cycling the lift again. This unit also has a 17% duty cycle, which means the liftgate can be cycled no more than 8 cycles/10 minutes constantly with a maximum load.

WARNING!

The following list of warnings are to be read before operating the TT series liftgate.

- Read this Owner's Manual and all of the decals on the liftgate BEFORE operating the liftgate.
- All protective covers and guards must be in place before operating the liftgate.
- DO NOT operate the liftgate if you do not have a thorough knowledge and understanding of the operation of the liftgate.
- NEVER OVERLOAD THE LIFTGATE. The maximum rated capacity of the TT12 series liftgate is as follows:

TT12 26" Deep Platforms - 1250 lbs. Maximum Load
TT12 30" and 32" Deep Platforms - 1000 lbs. Maximum Load
TT12 36" and 38" Deep Platforms - 800 lbs. Maximum Load

- Never use the liftgate if it makes any unusual noises, has vibrations, or fails to operate freely.
- Make certain that the area below the platform is clear before and at all times during the operation of the liftgate.
- Keep hands and feet clear of all pinch points.
- The platform must be in the closed position with the latches engaged before transit.
- Always load as close to the center of the platform and as close to the truck as possible. See Figure 1.
- Never operate lift trucks on or over any part of the platform.
- Load and unload the platform from the rear and not from the side of the platform.
- Only operate liftgate when vehicle is on level ground and parking brake is set.
- Follow the maintenance guide as outlined in this manual.
- DO NOT attempt any repairs unless you are a qualified and authorized THIEMAN distributor.
- If any repairs, adjustments, or maintenance not covered in this manual are required, contact your nearest Thieman distributor or the factory.
- DO NOT ride the liftgate, it is not intended as a personnel lift.
- This liftgate is intended for the use of loading and unloading cargo only, and is not to be used for anything other than this.
- DO NOT modify this liftgate. Altering this liftgate may cause serious personal injury or damage the liftgate and will void all warranties.
- DO NOT weld or attach a receiver hitch to the liftgate's bumper in any way. Connecting a trailer to the bumper in anyway except with a ball hitch mounted in the supplied bumper hole or with a pin directly through this hole may cause serious personal injury or damage the liftgate and will void all warranties.

WATER LEVEL LOADING

When a load is to be raised or lowered, this load must be centered from side to side on the load bearing platform. The load should also be closest to the edge of the platform nearest the truck. If a load is not uniformly distributed, then the heaviest portion should be closest to the edge of the platform nearest the truck.

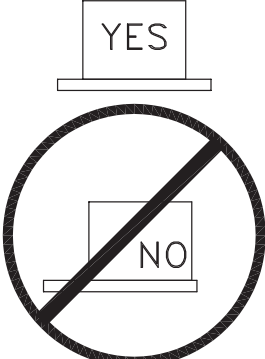
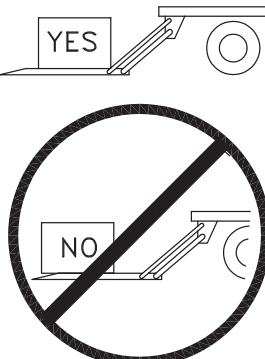
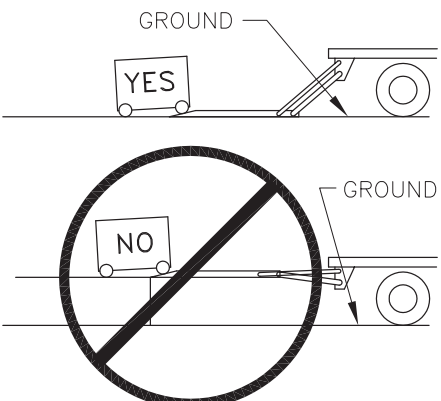
 WARNING		
<p>SIDE TO SIDE</p>  <p>DO NOT OFF CENTER LOAD</p>	<p>FRONT TO BACK</p>  <p>DO NOT OFF CENTER LOAD</p>	<p>GROUND</p>  <p>DO NOT LOAD OR UNLOAD WITH RAMP OFF GROUND</p>

4671050D

OPERATING INSTRUCTIONS

CAUTION:

Be sure to operate liftgate at a safe distance and never improperly load platform as this may cause personal injury or damage to the liftgate. **ALWAYS SET PARKING BRAKE BEFORE OPERATING THIS LIFTGATE!**

OPENING OF PLATFORM

- STEP 1: Remove safety cotter pin from curb side lock pin.
STEP 2: Disengage lock pins with one hand while holding platform upright with the other hand. Unfold platform using both hands until it is in the horizontal position.
STEP 3: Push toggle switch or control handle to lowering position and lower platform to the ground.

RAISING OF PLATFORM

- STEP 4: Push toggle switch or control handle to raise position and raise platform to bed height.

LOWERING OF PLATFORM

- STEP 5: Push toggle switch or control handle to lowering position and lower platform to the ground.

CLOSING

- STEP 6: Raise platform to bed height and manually fold platform to the vertical position and be sure both lock pins are engaged. Replace cotter pin in curb side lock pin.

WARNING: SWITCH OR HANDLE SHOULD ALWAYS BE IN THE NEUTRAL POSITION WHEN GATE IS NOT IN USE.

MAINTENANCE GUIDE

The following inspection and maintenance operations should be performed at the recommended intervals or anytime the liftgate shows signs of abuse, and improper or abnormal operation.

MONTHLY INSPECTION AND MAINTENANCE

Operate the liftgate throughout its entire operational cycle and check the following:

1. Check that there are no unusual noises or vibrations.
2. Check that the platform is level when raised to bed height.
3. Check for apparent damage to the liftgate such as bent or distorted members, any cracked welds, which may have resulted from overloading or abuse.
4. Check for any excessive wear in the following areas:
 - A. Platform Hinge Pins and Pivot Plates
 - B. All Pivot Points
 - C. All Cylinder Pins and Bolts
5. Check that all platform pivot pins are in place and retained by their proper retainers.
6. Check that all protective covers and guards are properly in place and secured.
7. Check for oil leaks in these areas:
 - A. Lift Cylinder
 - B. Hydraulic Hose-Replace if it shows signs of wear or cracking.
 - C. Hydraulic Fittings-Tighten or replace as may be required to stop leakage.
8. Check painted finish, if in poor condition, then repaint. Any rusted parts should be replaced.
9. Check condition of non-painted parts, replace if corrosion exists.

10. Check the oil level in the hydraulic reservoir. Release safety latches and lower gate to the ground, the oil should be visible in the bottom of the filler tube. See chart below.

HYDRAULIC FLUID CHART	
Temperature Range	Acceptable Fluids
-75 to 165 F	Exxon Univis J-26
-20 to 130 F	Dexron III Exxon Superflo ATF Shell Donax® TG
-50 to 80 F	Shell Aero Fluid 4 Mobil Aero HFA Exxon Univis J-13 MIL H-5606

11. Check that all wiring and battery cable connections are tight and free of corrosion.

12. Lubrication of the TT12 series gate should be as follows:

<u>Area of Tailgate</u>	<u>Type of Lubrication</u>	<u>Frequency</u>
Extension Pivots	SAE 10 to SAE 20 oil	50 cycles
Lift Arm Pivots	Grease	50 cycles
Idler Arm Pivots	Grease	50 cycles
Trunnion Tube	Grease	50 cycles
Pump Oil Change	See Above Chart	Yearly

* See the parts list for location of the grease zerks.

For -40 to 120F use #0 Grade Grease.

For -20 to 200F use #1 Grade Grease.

* The platform pivot points on the TT-12 have special bushings that do not require lubrication.

13. Check the pump relief pressure and also the motor amperage at this pressure. These values should be as follows:

Model	Max Amp Draw	Relief Pressure (psi)
TT12	160	1600

Semi-Annual Inspection

- Perform the procedures outlined in the "Monthly Inspection and Maintenance."
- Inspect pump motor by:
 - Disconnecting battery cable
 - Remove motor end cover
 - Examine the armature brushes for wear. (Brushes should be replaced if they are less than 1/8" long.)
 - Clean all residue out from inside of the motor housing.
 - Apply several drops of light weight machine oil to the armature shaft bearing in the motor cover end and reassemble the motor end cover.
- If the hydraulic oil in the reservoir is dirty:
 - Lower the platform completely to the ground.

- B. Drain the oil from the hydraulic system and flush the entire system.
- C. Remove reservoir from pump and clean suction line filter. Also, clean out any contaminants from reservoir. Remount reservoir when completed.
- D. Replace the oil as outlined in Section 8 under Monthly Maintenance and Inspection.

INSPECTION AND LOCATION OF DECALS

Inspect all of the decals listed below to be certain that they are in the proper location and they are legible. All decals must be in place and legible or all warranties are void!

Item	Part Name	Part Number
1	Warning Decal-Off Center	4671050
2	PTO Decal	4650140
2	Fast Idle Decal	4650150
3	Danger Decal-No Riding	4609
4	Operating Decal	4650520
5	Capacity Decal-1250#	4650060
5	Capacity Decal-1000#	4650050
5	Capacity Decal- 800#	4607-004
6	Warning Decal	4650530
7	Caution Decal-Working Area	4650770
8	Reflector(2)	5705
9	Thieman Nameplate	4650801
10	Wiring Decal	4612
11	Warning Decal-High Pressure	4620

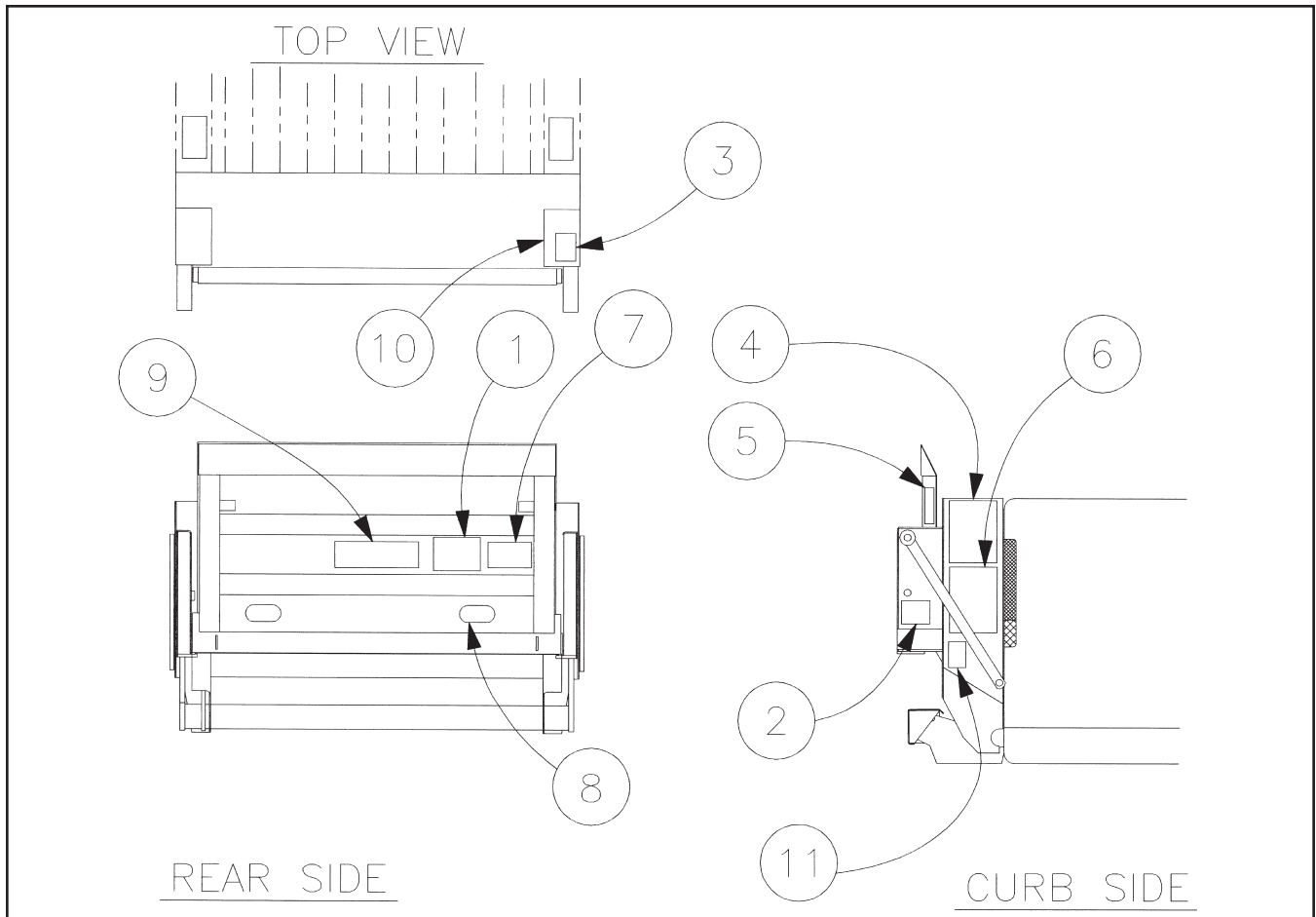

ELECTRICAL PICTORIAL

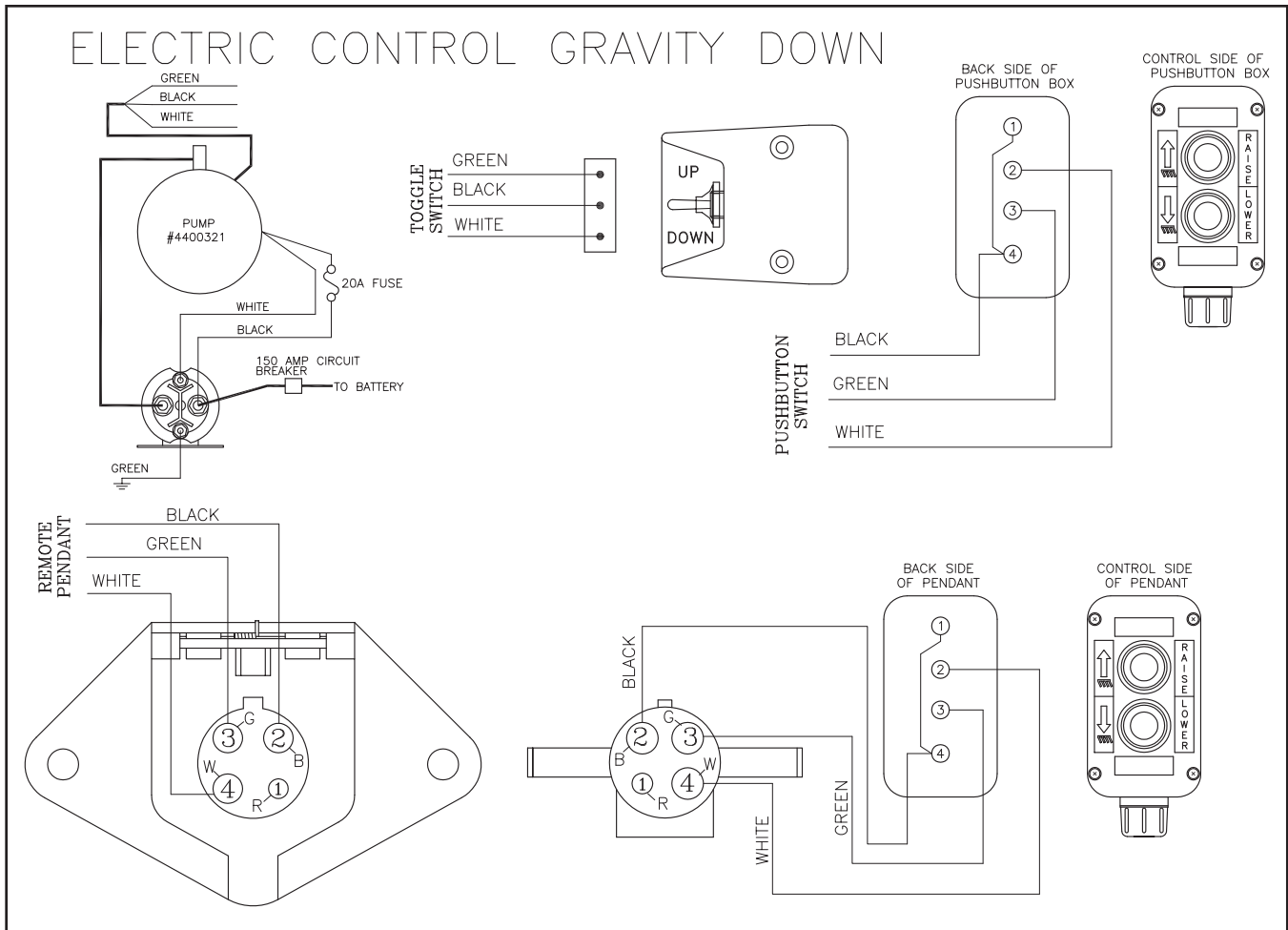

PARTS ORDERING PROCEDURE

When ordering parts, please include all the information asked for below. If this information is not available, a complete written description or sketch of the required part will help Thieman identify and deliver the needed part to you.

THE FOLLOWING INFORMATION MUST BE INCLUDED:

1. Serial Number - Thieman liftgate serial numbers can be found on the tag located on the curb side lift arm.
2. Model Number and Capacity.
3. Platform size and Material - Steel or Aluminum.
4. Part number.
5. Description.
6. Quantity required.

IMPORTANT

IT IS IMPORTANT THAT EVERY VEHICLE THAT HAS A THIEMAN LIFTGATE HAVE LEGIBLE WARNING AND OPERATION DECALS CLEARLY POSTED ON THE VEHICLE AND AN OWNER'S MANUAL IN THE VEHICLE AT ALL TIMES AS A GUIDE FOR PROPER OPERATION AND MAINTENANCE.

ADDITIONAL WARNING DECALS, OPERATION DECALS AND OWNER'S MANUALS CAN BE OBTAINED FROM THIEMAN TAILGATES, INC.

TT12 EPB

Item	Part Number	Description	Qty.
1	4400321	Pump Asm Incl 19, 24, 25	1
2	4294	Cylinder	1
3	31373	Clevis	1
4	8144113	Street Elbow .75	1
5	8219666	Pipe Nipple .75 x 6	1
6	8192090	Pipe Coupling .75	1
7	4420410	Breather Cap	1
8	4422850	Pushbutton Control	1
9	4477	Solenoid	1
10	4350	Terminal	1
11	4300030	Cable #2 x 25'	1
12	4933-001	Elbow BT-MAORB	2
13	5001860	Pin	1
14	4931-003	Restrictor Elbow MJ-MAORB	1
15	4921-009	Tube	1
16	4951-006	Hose 34"	1
16	4951-007	Hose 41" (59.50 wide)	1
17	4930-001	Elbow MJ-MAORB	1
18	4951-004	Hose 47"	1
19	4423520	Motor 8111	1
20	8271291	Zerk*	1
21	5781008	Retaining Ring	4
22	5001870	Pin	1
23	43024	Buss Bar	1
24	8120380	Lockwasher .25	2
25	8109-013	Screw .25 x 1.50	2
26	4937-001	Straight Adapter MJ-MJ	1
27	8120375	Nut .25	1
28	8120386	Flatwasher	1
29	8180022	Screw .25 x 1.00	1
30	4220240	Nylon Insert	1
31	8181635	Screw .38 x .75	1
32	4319-002	Heat Shrink	1
33	4301770	Circuit Breaker - 150A	1
34	4318-001	Battery Cable #2 x 2'	1
35	5701260	Cable Retainer	12

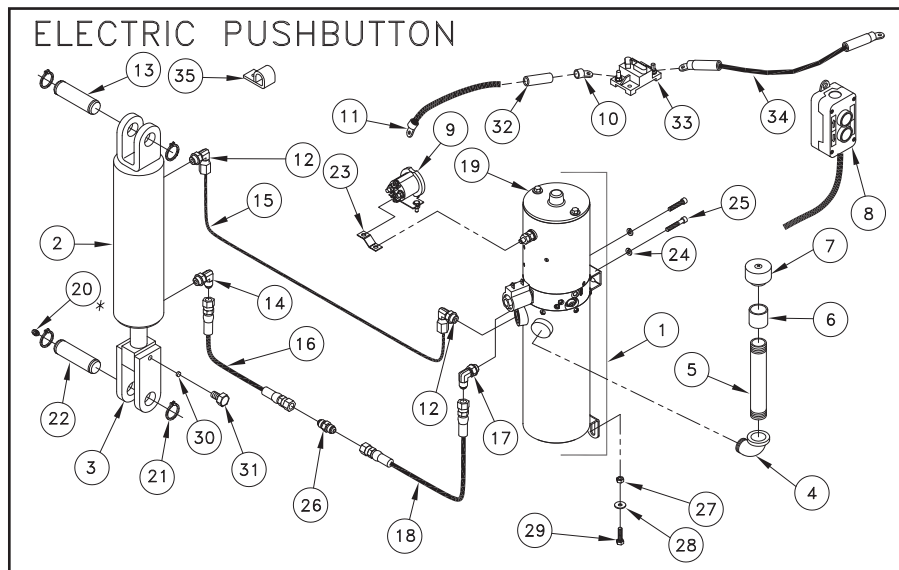

TT12 E

Item	Part Number	Description	Qty.
1	4400421	Pump Asm Incl 10 thru 12	1
2	4294	Cylinder	1
3	31373	Clevis Weld	1
4	8144113	Street Elbow .75	1
5	8219666	Pipe Nipple .75 x 6	1
6	8192090	Pipe Coupling .75	1
7	4420410	Breather Cap	1
8	4300030	Cable #2 x 25'	1
9	4350	Terminal	1
10	4423450	Bracket	1
11	4422980	Canister Switch	1
11	4420750	Dimmer Switch	1
12	4423520	Motor 8111	1
13	4421370	Cable	1
14	5701260	Cable Retainer	12
15	8109-013	Screw .25 x 1.50	2
16	8120380	Lockwasher .25	2
17	8180022	Screw .25 x 1.00	1
18	8120386	Flatwasher .25	1
19	8120375	Nut .25	1
20	5001870	Pin	1
21	8181635	Screw .38 x .75	1
22	4220240	Nylon Insert	1
23	5781008	Retaining Ring	4
24	8271291	Zerk*	1
25	4933-001	Elbow BT-MAORB	2
26	4921-009	Tube	1
27	4937-001	Straight Adapter MJ-MJ	1
28	4931-003	Restrictor Elbow MJ-MAORB	1
29	4930-001	Elbow MJ-MAORB	1
30	4951-006	Hose 34"	1
30	4951-007	Hose 41" (59.50 wide)	1
31	4951-004	Hose 47"	1
32	5001860	Pin	1
33	4319-002	Heat Shrink	1
34	4301770	Circuit Breaker - 150A	1
35	4318-001	Battery Cable #2 x 2'	1

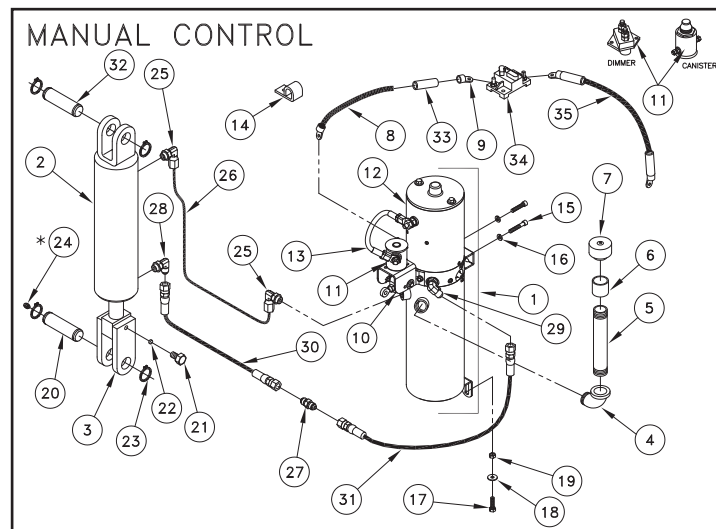

TT12

Item	Part Number	Description	Platform Width		
			53	56	60
1	31347-001	Lift Asm	1		
1	31347-002	Lift Asm		1	
1	31347-003	Lift Asm			1
2	2327010	Bumper Brace	2	2	2
3	3104100	Post Cover SS	1	1	1
4	3104090	Post Cover - Manual Control	1	1	1
4	3104110	Post Cover - Pushbutton	1	1	1
5	3801008	Latch Cable	1	1	1
6	3104080	Handle	1	1	1
7	2502050	Linkage	1	1	1
8	5701041	Handle Grip	1	1	1
9	8449646	Screw .25 x .62	4	4	4
10	8180126	Screw .38	1	1	1
11	8120388	Flatwasher	12	12	12
12	8120377	Nut .38	1	1	1
13	9413534	Locknut .38	5	5	5
14	3435-001	Platform**	1		
14	3435-002	Platform**		1	
14	3435-003	Platform**			1
15	3103132	Pivot Support CS	1	1	1
16	3103131	Pivot Support SS	1	1	1
17	2101820	Idler Arm	2	2	2
18	5702020	Bumper	1	1	1
19	31357-001	Cable Asm	1		
19	31357-002	Cable Asm		1	
19	31357-003	Cable Asm			1
20	5101160	Spring	2	2	2
21	8120396	Flatwasher	4	4	4
22	8121222	Cotter Pin	2	2	2
23	4300550	Light	2	2	2
24	23048	Backer Plate	2	2	2
25	8180177	Screw .50 x 1.50	4	4	4
26	8120384	Lockwasher .50	4	4	4
27	8120378	Nut .50	4	4	4
28	5702280	Screw	2	2	2
29	5702270	Plastic Square Nut	2	2	2
30	5010	Pin Lift Arm	2	2	2
31	5781008	Retaining Ring	4	4	4
32	5701200	Grommet	2	2	2
33	8271291	Zerk*	10	14	14
34	5702371	Spring Pin	2	2	2
35	27091-002	Post Support - RH	1	1	1
36	27091-001	Post Support - LH	1	1	1
37	5700022	Hairpin	1	1	1
38	5702230	Cable Retainer	1	1	1
39	2043	Mounting Angle	2	2	2
40	5504-011	Bushing***	2	2	2
41	8180122	Screw .38 x 1.00	4	4	4
42	3074	Post Support Spacer Tube		2	
43	23124	Spacer Plate		2	
44	8107-007	Flatwasher	2	2	2

* For maintenance, look at the following page for grease fitting locations

** Consult the factory for the part numbers of special platforms

*** Consult the factory for the quantities of this bushing on special platforms

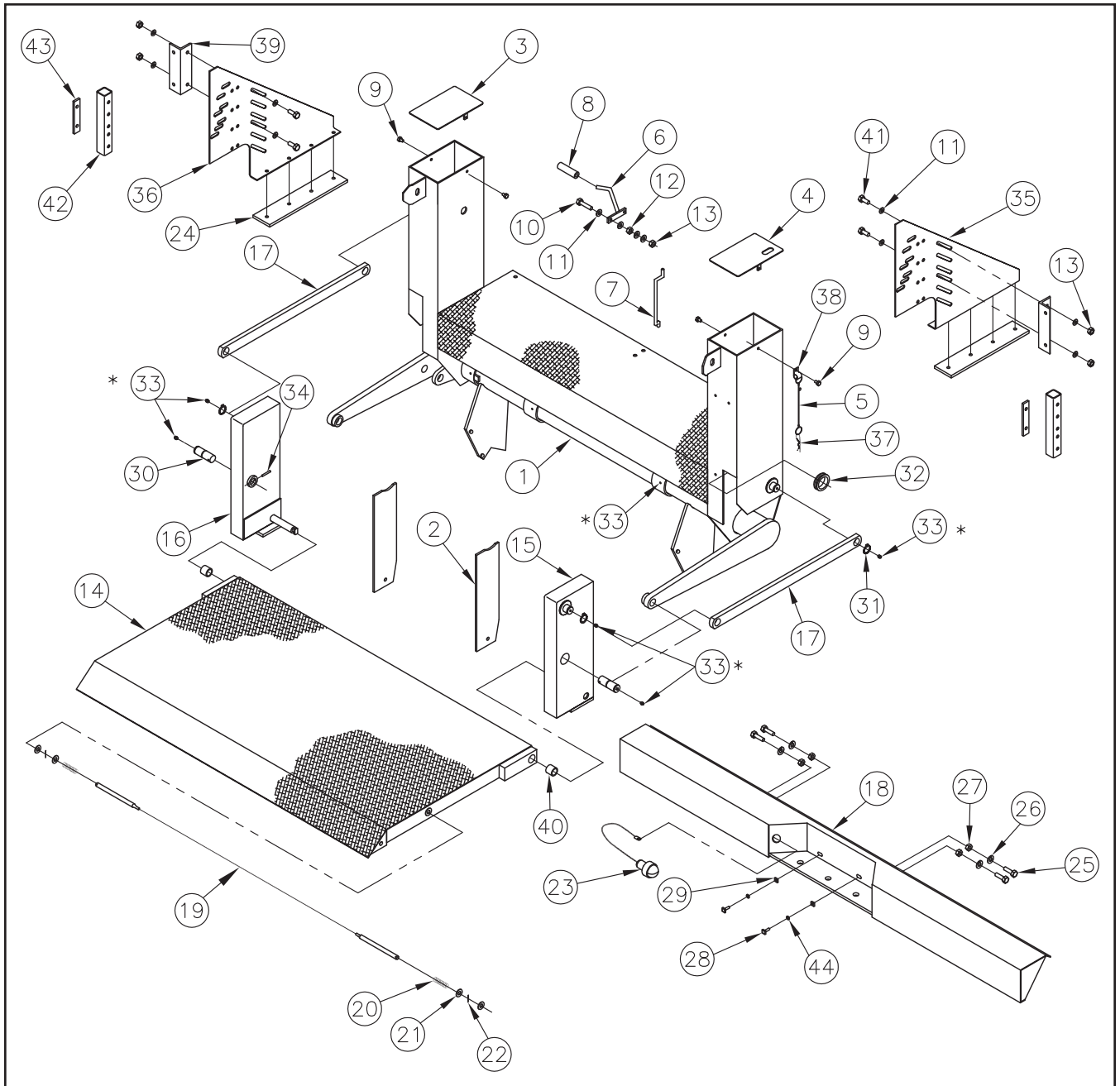

TROUBLESHOOTING GUIDE TT12E

- Test Equipment:**
1. 0-5000 psi pressure gauge
 2. DC voltmeter/ohm meter
 3. DC amp meter
 4. standard mechanics tools

Note: Please refer to the electrical diagrams and hose connection drawings in the liftgate's owners manual when troubleshooting. This guide is only for standard Thieman liftgates. Special liftgates with options other than those in the owner's manual will require special diagrams for troubleshooting. Read and understand this entire guide completely before doing any troubleshooting. Certain listed problems may be related to other problems listed so a comprehensive knowledge is required before proceeding.

1. Problem - Pump motor will not run in the raise mode
 - Causes -
 - a. Tripped circuit breaker
 - b. Defective or undercharged battery(ies)
 - c. Improper battery cable connection or improper ground connection
 - d. Bent or broken linkage
 - e. Defective start switch
 - f. Defective pump motor
 - Corrections -
 - a. Reset the circuit breaker located within 2ft of the liftgate supply battery(ies).
 - b. The "at rest" voltage for the batteries without the engine running and under no load should be at least 12.5V. The minimum voltage between the motor stud and ground is 9V at maximum load conditions. If proper voltage is not present, charge or replace the batteries. The battery(ies) on the vehicle should be that which has a minimum 150 amp reserve capacity.
 - c. Trace battery and ground cable connections to locate improper connection(s). Make sure the ground cable is installed going from the aluminum pump base to bare metal on the truck frame. Make sure the ground cable from the batteries to the frame is a heavy 2ga. cable and that it too is connected to bare metal on the frame. Make sure there is 12.5V present at the motor start switch where the 2ga. cable from the batteries is connected. Replace any damaged cables and repair any bad connections.
 - d. Check that the cam on the pump which engages the motor start switch is fully depressing the button on the switch. If not, repair or replace the linkage rod and pins.
 - e. Check for voltage on the motor stud when the switch is activated. If no voltage exists the motor start switch will need to be replaced.
 - f. With the control lever activated in the "RAISE" position and the motor start switch is activated, check for voltage at the motor terminal. If voltage is present and the motor is not running, replace the motor.

2. Problem - Liftgate will not raise to bed with a load and the pump motor running
 - Causes -
 - a. Low hydraulic fluid
 - b. Overload condition
 - c. Improperly adjusted or defective main relief valve
 - d. Lift cylinder is bypassing, liftgate is drifting down
 - e. Broken hydraulic line
 - f. Clogged or disconnected suction line
 - g. Defective pump

- Corrections -
- a. Make sure the reservoir has the proper amount of fluid. Remove the breather cap and check the fluid level through the fill hole. The hydraulic fluid should be at the bottom of the fill tube with the liftgate in the lowered position. Fill with Dexron III automatic transmission fluid.
 - b. The power unit on the TT12 is equipped with a lifting relief valve to prevent overloading of the liftgate. See relief setting in "Maintenance Guide" section of this manual.
 - c. See section "b" above for relief valve setting. Plumb a pressure gauge into the high pressure circuit of the liftgate. Remove all loads from the liftgate's platform. Engage the "RAISE" lever until the liftgate is fully raised. Keep the "RAISE" lever engaged until the pump bypasses through the relief valve and note the pressure on the gauge at this time. If the rated relief pressure is not present during relief, adjust the high pressure relief valve setting as necessary. If the relief pressure is not attainable the relief valve must be cleaned and/or replaced or the pump is defective. See section "g" below.
 - d. If the liftgate will not raise with a load on the platform but empty is raising slowly or only partially, the cylinder may be bypassing. To check for a bypassing cylinder do the following. Lower the gate to the ground to relieve all pressure from the cylinder. Disconnect the cylinder from the liftarm. Press the "RAISE" lever until the cylinder is fully retracted. Disconnect the return line from the power unit and put the end of the line in a container to catch any oil which comes out during this test. Press the "RAISE" lever for 15 to 20 seconds and watch for a steady stream of fluid coming out of the return line into the container. If no steady stream of oil is present connect the hose to the butt end of the cylinder after removing the return line and fitting. Re-attach the return line and fitting to the rod end port. Put the loose end of the return line in a container to catch any oil, which comes out during this test. Press the "RAISE" lever until the cylinder is fully extended. Press the "RAISE" lever for 15 to 20 seconds and watch for a steady stream of fluid coming out of one of the disconnected hose ends into the container. Replace or rebuild any cylinder with fluid coming out of the return line, as this indicates fluid is bypassing the piston seals on the cylinder. Reconnect rebuilt or replaced cylinders and hoses as before.
 - e. Broken or punctured hydraulic lines and fittings must be replaced with care to avoid injury from high pressure oil streams.
 - f. With the liftgate at the ground, disconnect the power unit and remove the reservoir. Check to see if the suction tube is clogged or has fallen out of the pump base. Clean the screen or reattach the suction tube as required.
 - g. If all else fails replace the power unit, it is probably worn out.

3. Problem - Liftgate will not lower

Causes

- a. Bent or broken linkage
- b. Defective lowering valve
- c. Clogged or defective hydraulic lines, fittings or flow controls

Corrections-

- a. See section 1d
- b. Manually depress the lowering valve on the pump. If the liftgate does not lower then replace this valve by supporting the liftgate so as to relieve the pressure on the hydraulic system. Remove the solenoid bracket and screw out the cartridge valve. Clean or replace as necessary.
- c. Remove any obstruction in the hoses, fittings or flow controls or replace any hose, fitting or flow control, which does not allow fluid to flow through freely.

4. Problem - Liftgate raises slowly - The raise speed of the TT12 on a 36" bed height while empty at 70° F is approximately 5-7 seconds. The raise speed loaded for the same conditions is approximately 10-12 seconds.

- Causes -
- a. Overload condition
 - b. Cold weather
 - c. Partially blocked suction screen
 - d. Lift cylinders are bypassing
 - e. Improperly adjusted or defective raise relief valve
 - f. Low voltage and/or bad ground
 - g. Worn out pump

- Corrections -
- a. See section 2a
 - b. Refer to Owner's Manual for alternative oils to use for cold weather conditions.
 - c. Remove reservoir and clean or replace suction screen as necessary.
 - d. See section 2d
 - e. See section 2c
 - f. The minimum voltage between the motor stud and ground is 9.5 volts at maximum load conditions. See section 1b and 1c.
 - g. After all other corrections are performed it will be necessary to replace the pump.

5. Problem - Foamy oil flowing from reservoir breather

Causes -

- a. Air is present in the system

- Corrections -
- a. Air can enter the system if the fluid level is low, see problem 2, part a, or if the suction tube is disconnected, see problem 2, part f. Also air may enter through fittings, which are not tightened properly, so check for any leaks around fittings or hoses. Once the source of the air is determined, the cylinder must be bled of all air. Most air can be removed from the system by lowering the gate to the ground to relieve all pressure from the cylinder, unpinning the cylinder and cycling it back and forth several times from fully extended to fully retracted and allowing the pump to bypass through the relief valves for a few seconds in each direction.

If you have any questions or problems that are not covered in this guide please call Thieman's Engineering Department at 1-800-524-5210.

