

STOWAWAY® **SIDE**LOADER

Tailgates By THIEMAN

SL15/20-6 AND SL15/20-10 OWNERS MANUAL/PARTS LIST

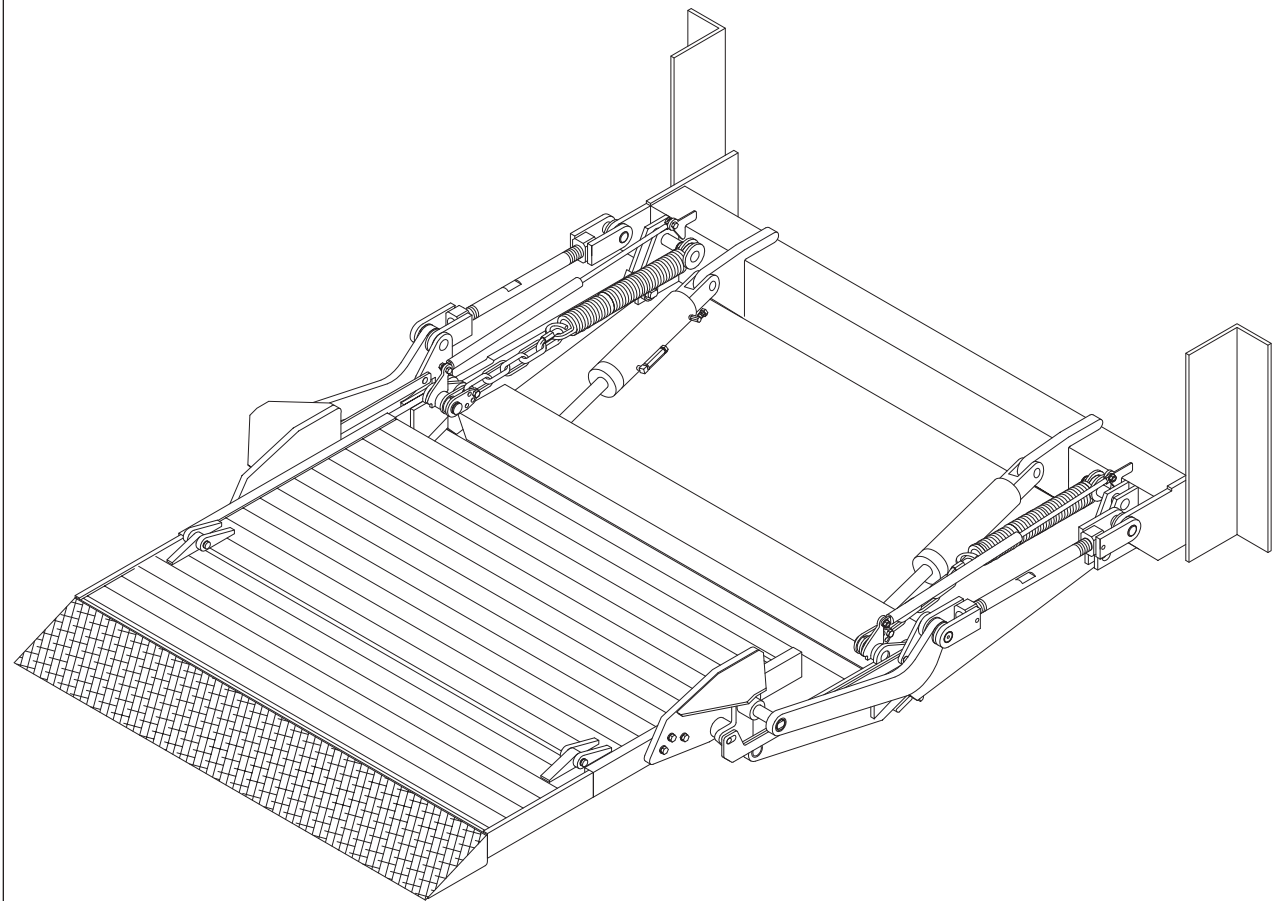

IMPORTANT! KEEP IN VEHICLE!

PLEASE READ AND UNDERSTAND THE CONTENTS OF THIS
MANUAL BEFORE OPERATING THE EQUIPMENT.



THIEMAN
TAILGATES, INC.

600 East Wayne Street
Celina, Ohio 45822

Phone: 419-586-7727 Fax: 419-586-9724

TABLE OF CONTENTS

PARTS ORDERING PROCEDURE	2
WARNINGS	3
OPERATING INSTRUCTIONS.....	4
MAINTENANCE GUIDE.....	5
SEMI-ANNUAL INSPECTION	6
INSPECTION AND LOCATION OF DECALS	6,7
ELECTRICAL PICTORIALS	7,8
PUMP ASM - TOGGLE CONTROL.....	8,9
TRUNNION, LIFT ARM, AND IDLER ARM ASM-10".....	10,11
TRUNNION, LIFT ARM, AND IDLER ARM ASM-6"	12,13
PLATFORM ASM	14
SPRING ASSIST ADJUSTMENT.....	15
TROUBLESHOOTING GUIDE	16-19

FOR YOUR RECORDS

Model No. _____ Date Purchased _____

Serial No. _____

NOTE: WHEN ORDERING PARTS BE SURE TO INCLUDE THIS INFORMATION!

PARTS ORDERING PROCEDURE

When ordering parts, please include all the information asked for below. If this information is not available, a complete written description or sketch of the required part will help Thieman identify and deliver the needed part to you.

THE FOLLOWING INFORMATION MUST BE INCLUDED:

1. Serial Number - Thieman liftgate serial numbers can be found on the tag located on the front side of the trunnion tube.
2. Model Number and Capacity.
3. Platform size and Material - Steel or Aluminum.
4. Part number.
5. Description.
6. Quantity required.

WATER LEVEL LOADING

When a maximum load is to be raised or lowered, this load must be centered on the load bearing platform, both front to back and side to side.

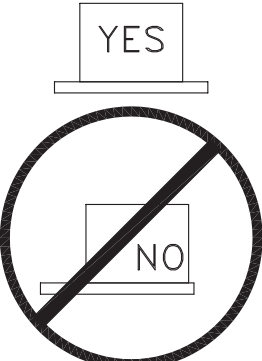
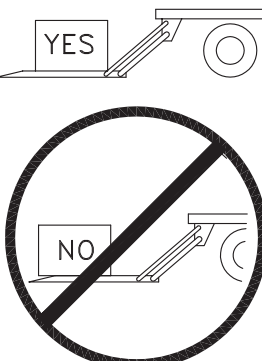
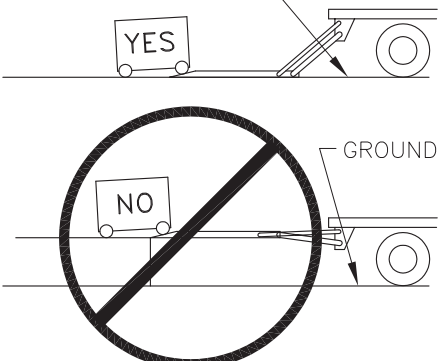
 WARNING		
<p>SIDE TO SIDE</p>  <p>DO NOT OFF CENTER LOAD</p>	<p>FRONT TO BACK</p>  <p>DO NOT OFF CENTER LOAD</p>	<p>GROUND</p>  <p>DO NOT LOAD OR UNLOAD WITH RAMP OFF GROUND</p>
<small>4671050D</small>		

WARNING!

The following list of warnings are to be read before operating the SL series liftgate.

- + Read this Owner's Manual and all of the decals on the liftgate **BEFORE** operating the liftgate.
- + All protective covers and guards must be in place before operating the liftgate.
- + **DO NOT** operate the liftgate if you do not have a thorough knowledge and understanding of the operation of the liftgate.
- + **NEVER OVERLOAD THE LIFTGATE.** The maximum rated capacity of the SL series liftgate differs with each model as follows:
 - SL15 - 1500lbs.
 - SL 20 - 2000lbs.
- + Never use the liftgate if it makes any unusual noises, has vibrations, or fails to operate freely.
- + Make certain that the area below the platform is clear before and at all times during the operation of the liftgate.
- + Keep hands and feet clear of all pinch points.

- + The platform must be in the closed position and the transit chains attached properly before transit.
- + Always load as close to the center of the platform and as close to the vehicle as possible. See Figure 1.
- + Never operate lift trucks on or over any part of the platform.
- + Load and unload the platform from the rear and not from the side of the platform.
- + Only operate liftgate when vehicle is on level ground and the parking brake is set.
- + Follow the maintenance guide as outlined in this manual.
- + DO NOT attempt any repairs unless you are a qualified and authorized THIEMAN distributor.
- + If any repairs, adjustments, or maintenance not covered in this manual are required, contact your nearest Thieman distributor or the factory.
- + DO NOT ride the liftgate, it is not intended as a personnel lift.
- + This liftgate is intended for the use of loading and unloading cargo only, and is not to be used for anything other than this.
- + DO NOT modify this liftgate. Altering this liftgate may cause serious personal injury or damage the liftgate and will void all warranties.

OPERATING INSTRUCTIONS

Caution

Be sure to operate liftgate at a safe distance and never improperly load platform as this may cause personal injury or damage to the liftgate.

UNFOLDING OF PLATFORM

1. Raise platform by pushing the raise switch up until tension is removed from stow chains.
2. Unhook stow chains from lift arms.
3. Lower platform by pushing the lower switch until the platform is approximately 3/4 of the way to the ground.
4. Using platform handles, manually lift and pull platform until lift arms are fully extended.
5. Manually unfold platform extension and ramp.

RAISING OF PLATFORM

1. Push raise switch to raise platform to bed height.

LOWERING OF PLATFORM

1. Push lower switch to lower platform to the ground.

CLOSING OF PLATFORM

1. Raise platform approximately 6" from the ground.
2. Manually fold platform extension and ramp.
3. Using platform handles, manually lift and push platform into the folded position.
4. Raise gate into the stowed position.
5. Attach stow chains to lift arms.

THERMAL DATA: To avoid overheating the motor do not operate this unit for more than 14 cycles/10 minutes with the maximum load. The motor then must be allowed to completely cool down to ambient temperature before cycling the lift again. This unit also has a 12% duty cycle, which means the liftgate can be cycled no more than 5 cycles/10 minutes constantly with a maximum load.

MAINTENANCE GUIDE

The following inspection and maintenance operations should be performed at the recommended intervals or anytime the liftgate shows signs of abuse, and improper or abnormal operation.

MONTHLY INSPECTION AND MAINTENANCE

Operate the liftgate throughout its entire operational cycle and check the following:

1. Check that there are no unusual noises or vibrations.
2. Check platform height relative to bed height. If platform is lower, adjust cylinder with a 13/16 wrench to obtain the necessary height.
3. Check for apparent damage to the liftgate such as bent or distorted members, any cracked welds that may have resulted from overloading or abuse.
4. Check for excessive wear in the following areas:
 - A. Platform hinge pins and bushings
 - B. All cylinder pins, bolts, and bushings
5. Check that the platform pivot pins are in place and retained by their proper retainers.
6. Check that all protective covers and guards are properly in place and secured.
7. Check for oil leaks in these areas:
 - A. Lift cylinder
 - B. Hydraulic hose – replace if it shows signs of wear or cracking.
 - C. Hydraulic fittings – tighten or replace as may be required to stop leakage.
 - D. Hydraulic dampers – replace leaking damper with new hydraulic damper.
8. Check the oil level in the pump reservoir. With the liftgate in the stowed position the oil should be within 1/2" from the top of the reservoir. See chart below for oil applications.
9. Check that all wiring and battery cable connections are tight and free of corrosion.
10. Lubrication of the SL series liftgate should be as follows for all user conditions:

<u>Area of Tailgate</u>	<u>Type of Lubrication</u>	<u>Frequency</u>
Pivot pins w/ zerk	Grease+	50 cycles
Pump oil change	see chart below	yearly

*Most of the pivot points on the SL have special bushings that do not require lubrication.

+See the parts list for the location of the grease zerks.

For -40 to 120 F use #0 Grade grease.

For -20 to 200 F use #1 Grade grease.

HYDRAULIC FLUID CHART

Temperature Range	Acceptable Fluids
-20 to 130 F	Dexron III Exxon Superflo ATF Shell Donax TG
-50 to 80 F	Shell Aero Fluid 4 Mobil Aero HFA Exxon Univis J-13 MIL H-5606
-75 to 165 F	Exxon Univis J-26

11. Check the pump relief pressure and also the motor amperage at this pressure. These values should be as follows:

<u>Model</u>	<u>Max Amp Draw</u>	<u>Relief Pressure (psi)</u>
SL-15	170	1850
SL-20	190	2450

Semi-Annual Inspection

1. Perform the procedures outlined in the Monthly Inspection and Maintenance.
2. Repaint original painted components as necessary to prevent rust and corrosion from reducing structural integrity of original components.
3. Inspect pump motor by:
 - A. Disconnecting battery cable
 - B. Remove motor end cover
 - C. Examine the armature brushes for wear. (Brushes should be replaced if they are less than 1/8" long.)
 - D. Clean all residue out from inside of the motor housing.
 - E. Apply several drops of light weight machine oil to the armature shaft bearing in the motor end cover and reassemble the motor end cover.
4. If the hydraulic oil in the reservoir is dirty:
 - A. Unfold platform and lower platform to the ground. Raise platform to bed height so cylinders are fully retracted. Support the platform in this position with a lift truck or crane.
 - B. Drain the oil from the hydraulic system and flush the entire system.
 - C. Remove reservoir from pump and clean suction line filter. Also clean out any contaminants inside reservoir. Remount reservoir when completed.
 - D. Replace the oil as outlined in Section 9 under Monthly Maintenance and Inspection.

INSPECTION AND LOCATION OF DECALS

Item	Part Name	Part Number
1	Warning Decal-off center	4671050
2	Fast Idle Decal	4650150
3	Danger Decal-no riding	4609
4	Operating Decal	4606
5	Capacity Decal-1500#	4650070
5	Capacity Decal-2000#	4650100
6	Warning Decal-pinch point	4604
7	Handle Decal	4605
8	Wiring Decal	4614
9	Urgent Warning	4650530
10	Warning Decal-High Pressure	4620

INSTALL DECALS AS SHOWN

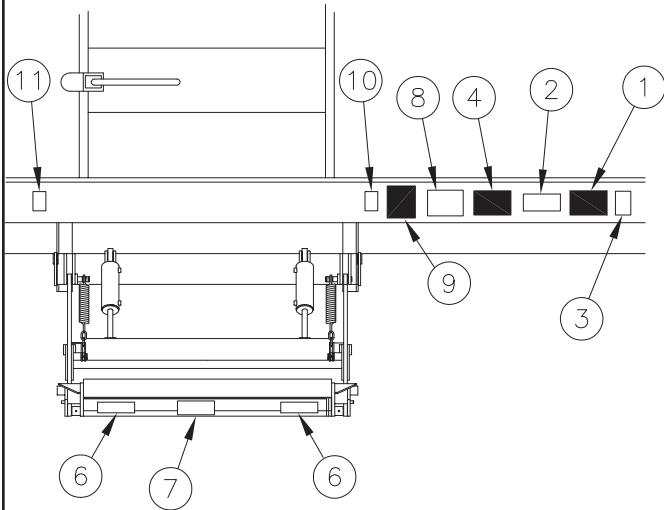

CURB SIDE RUB RAIL VIEW

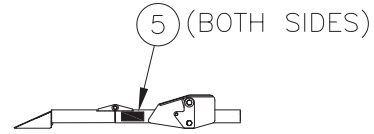

ELECTRICAL PICTORIALS

POWER DOWN ELECTRIC CONTROL (TOGGLE, PUSHBUTTON, OR REMOTE PENDANT)

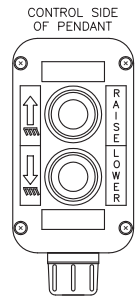
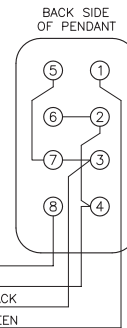
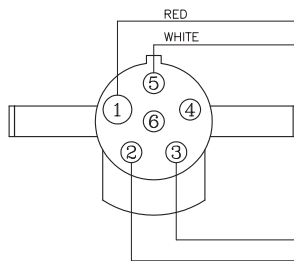
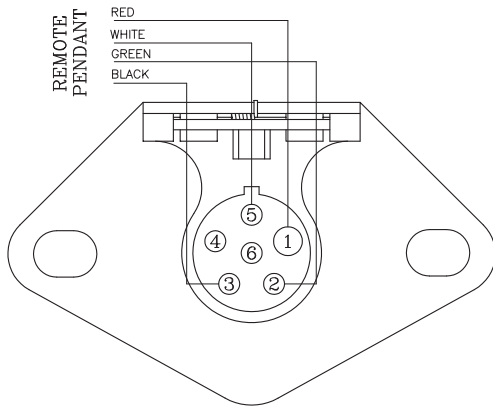
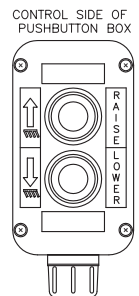
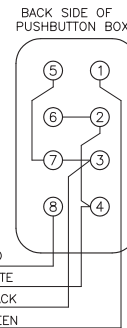
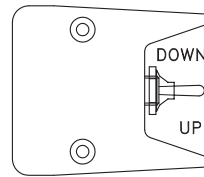
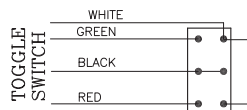
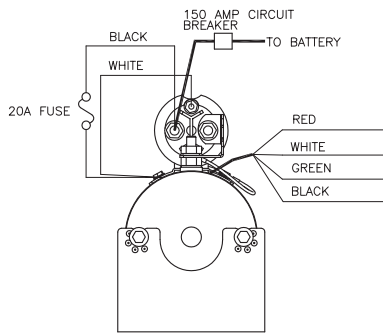

POWER DOWN ELECTRIC CONTROL (TOGGLE OR REMOTE W/ LOW VOLTAGE SWITCH-THERMAL SWITCH)

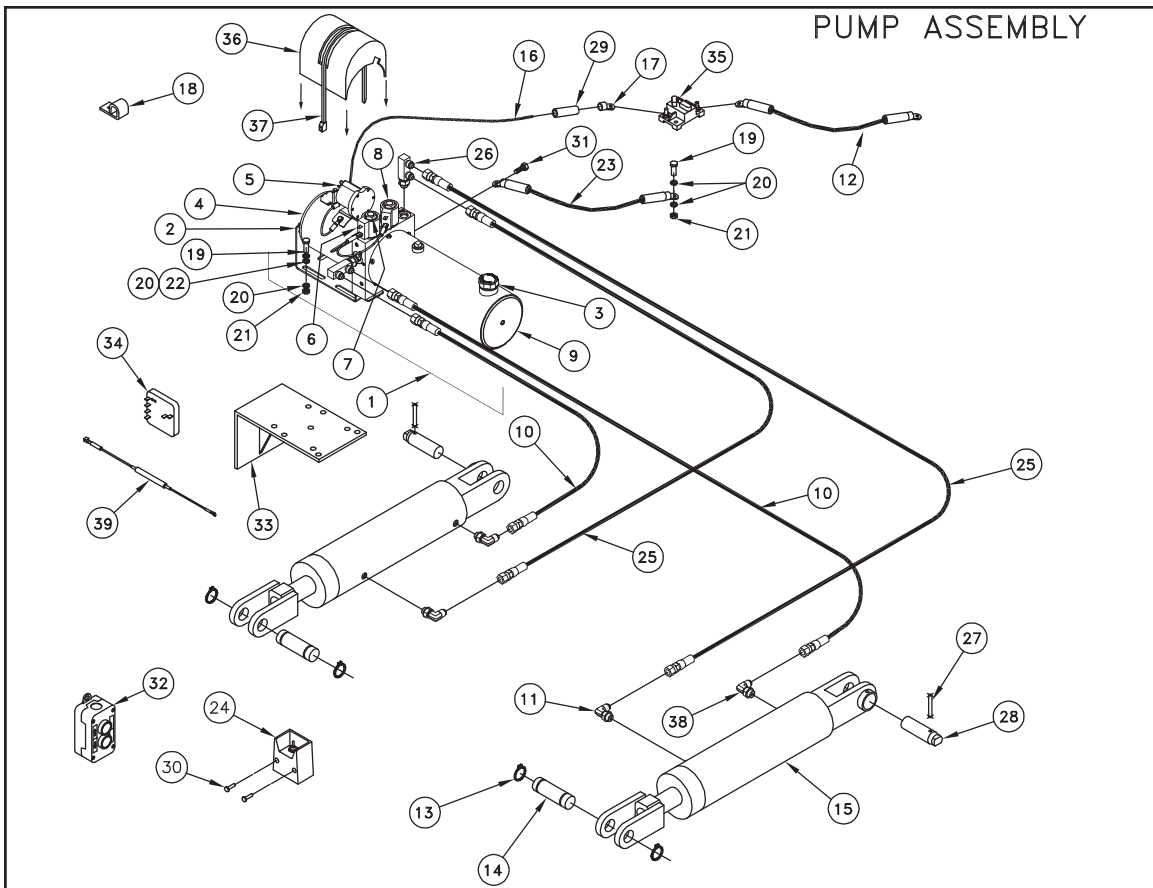
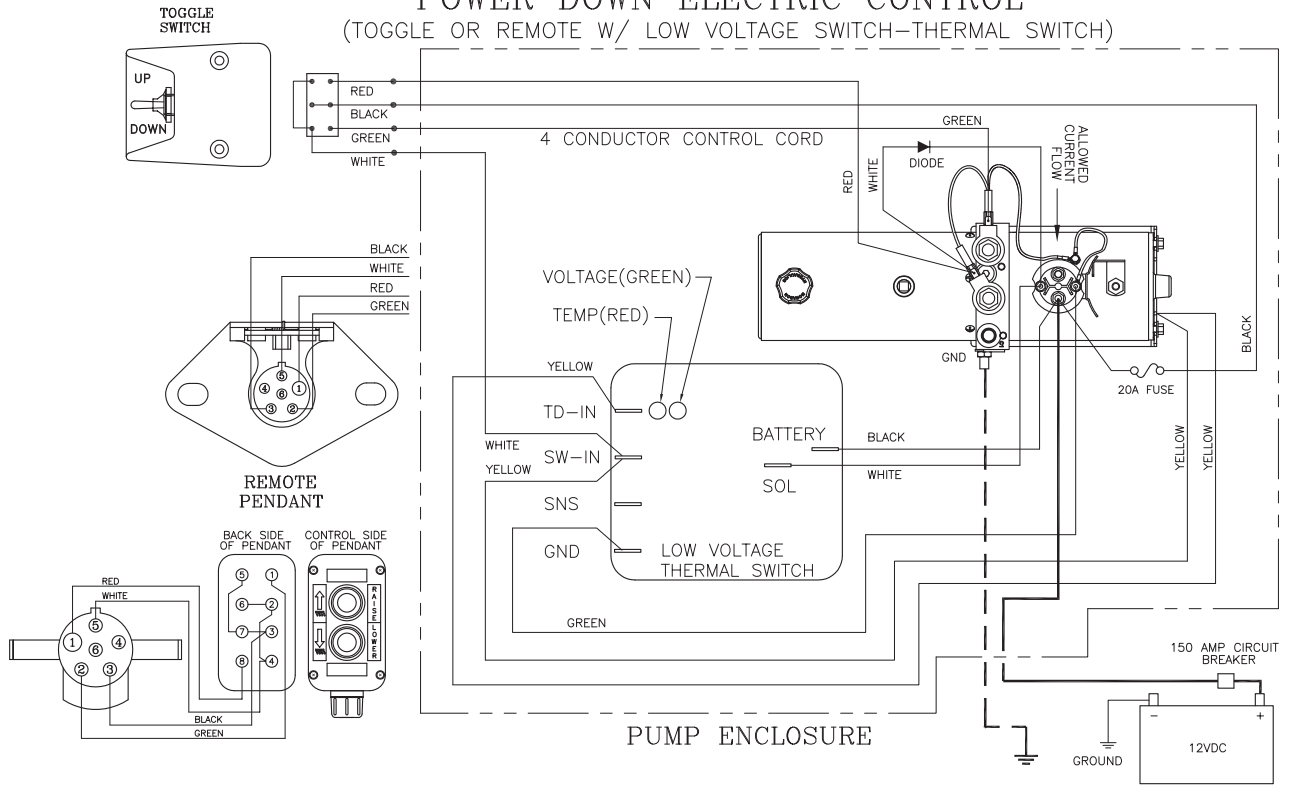

PUMP ASSEMBLY

Item	Part Number	Description	Qty
1	4404	EST Pump Asm-incl 2 to 9	1
1	4483	EST Pump (With thermal switch)	1
2	4421420	Pump bracket	1
3	4420410	Breather Cap	1
4	4423520	Motor 8111 (4404 PUMP)	1
4	4484	Motor 8045-I (4483 PUMP)	1
5	4468	Solenoid	1
6	4452	Solenoid Coil only	2
7	4445	Solenoid Valve Asm (lower)	1
8	4438	Solenoid Valve Asm (raise)	1
9	4457	Reservoir Ø4.50 x 10	1
10	4951-015	Hose 51.00	2
11	4931-002	Restrictor MJ-MAORB 90°	2
12	4318-002	Battery Cable #2x2'	1
13	5781008	Retaining ring	4
14	5009	Pin	2
15	31478	Cylinder 3 x 6	2
16	4300030	Battery cable #2 x 25'	1
17	4350	Cable lug	1
18	5701260	Cable retainer	4
19	8180126	Screw .38-16 x 1.50	5
20	8106-010	Internal Tooth Lockwasher .38	10
21	8120377	Nut .38	5
22	8120388	Flatwasher .38	4
23	4318-002	Ground Cable #2 x 2'	1
24	31445	Toggle Switch Asm	1
25	4951-013	Hose 84.00	2
26	4935	"F" Fitting	2
27	5702371	Spring pin	2
28	5024	Pin	2
29	4319-002	Heat Shrink	1
30	8111-005	Screw #10 x .75	2
31	8104-006	Screw .31 x 1	1
32	4422860	Pushbutton Control	1
33	31057	Pump Mounting Bracket	1
34	43045	Low Voltage Thermal Switch	1
35	4301770	Circuit Breaker 150A	1
36	5704	Cover	1
37	5700100	Strap	1
38	4930-001	MJ-MAORB 90°	2
39	43048	Diode Asm.	1

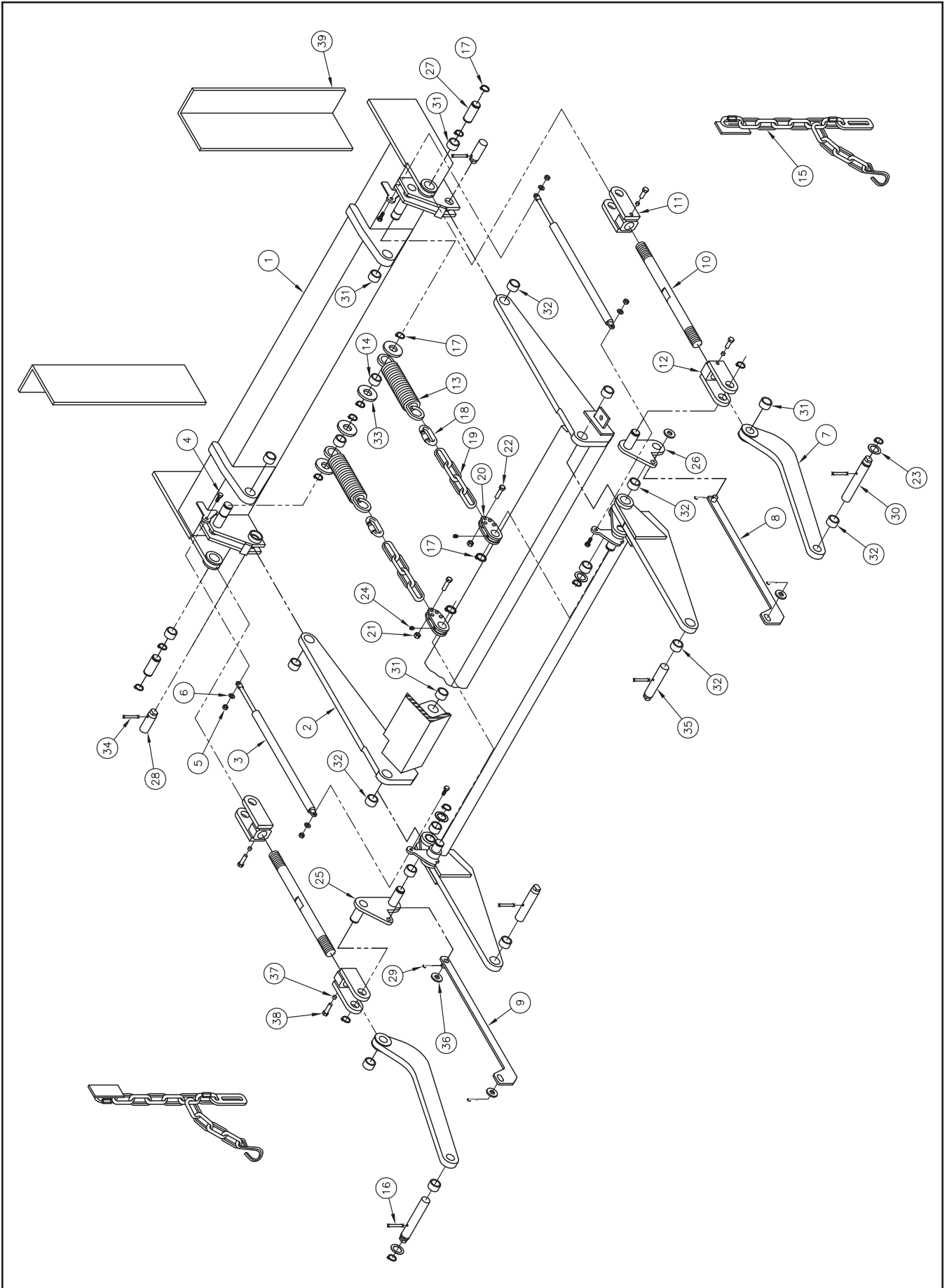

TRUNNION, LIFT ARM, & IDLER ARM ASM-10”

Item	Part Number	Description	Qty
1	31046	Trunnion asm (48 wide)	1
1	31610	Trunnion asm (60 wide)	1
2	31603	Lift arm asm (48 wide)	1
2	31605	Lift arm asm (60 wide)	1
3	5770	Hydraulic Damper	2
4	8104-012	SS Screw .31-18x1.00	4
5	8103-013	SS Locknut .31 (nylon ins)	4
6	8107-004	SS Flatwasher .31	4
7	31059	Idler arm	2
8	3110-002	Strap weld RH	1
9	3110-001	Strap weld LH	1
10	5019	Adjustment rod	2
11	31374	Clevis LH thread	2
12	31373	Clevis RH thread	2
13	5101120	Spring	2
14	5507-001	Bronze Bushing	2
15	31606	Chain Asm	2
16	5708-001	Spring pin	4
17	5781008	Retaining ring	16
18	4103	Chain Link	2
19	4109-019	Chain-Four Links	2
20	31595	Spring Link Weld	2
21	9413534	Locknut .38	2
22	5793002	Screw .38 x 1.25	2
23	8107-008	Flatwasher 1.00	4
24	8271291	Zerk	6
25	31284-001	Leveling strap LH	1
26	31284-002	Leveling strap RH	1
27	5009	Pin	2
28	5024	Pin	2
29	8121222	Cotter Pin	4
30	5018	Pin	2
31	5504-001	Bushing	8
32	5504-005	Bushing	12
33	8107-010	Flatwasher 1.00	2
34	5702371	Spring pin	2
35	5017	Pin	2
36	8120396	Flatwasher .50	4
37	4220240	Insert	4
38	8181635	Screw .38-24 x .75	4
39	2037000	4 x 6 x .38 angle	2

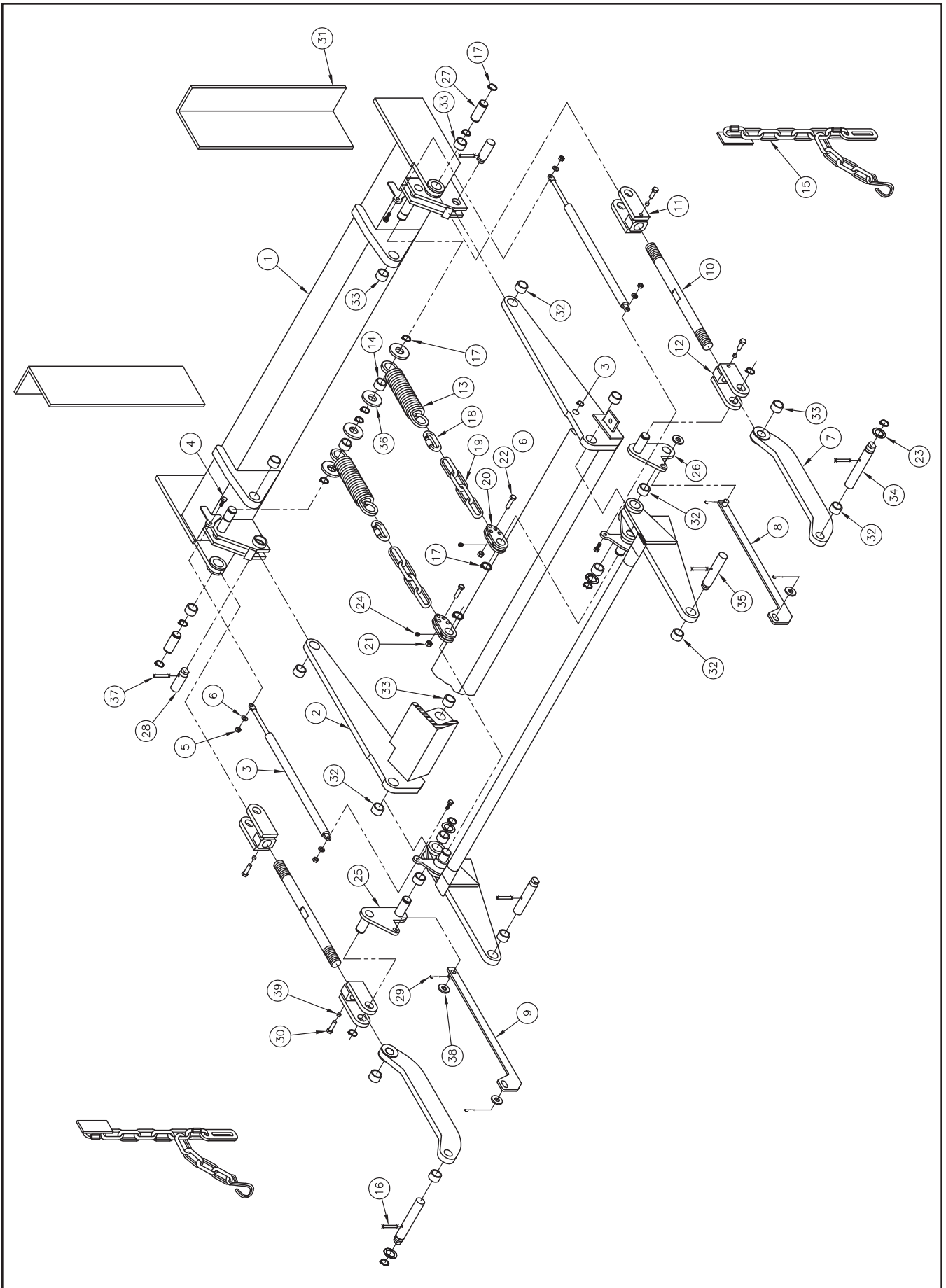

TRUNNION, LIFT ARM, & IDLER ARM ASM-6"

Item	Part Number	Description	Qty
1	31046	Trunnion asm (48 wide)	1
1	31610	Trunnion asm (60 wide)	1
2	31599	Lift arm asm (48 wide)	1
2	31607	Lift arm asm (60 wide)	1
3	5770	Hydraulic damper	2
4	8104-012	SS Screw .31-18x1.00	4
5	8103-013	SS Locknut .31 (nylon ins)	4
6	8107-004	SS Flatwasher .31	4
7	31058	Idler arm	2
8	31062-002	Strap weld RH	1
9	31062-001	Strap weld LH	1
10	5019	Adjustment rod	2
11	31374	Clevis LH thread	2
12	31373	Clevis RH thread	2
13	5101120	Spring	2
14	5507-001	Bronze Bearing	2
15	31606	Chain Asm	2
16	5708-001	Spring pin	4
17	5781008	Retaining ring	16
18	4103	Chain Link	2
19	4101-019	Chain-Four Link	2
20	31595	Spring Link Weld	2
21	9413534	Locknut .38	2
22	5793002	Screw .38 x 1.25	2
23	8107-008	Flatwasher 1.00	4
24	8271291	Zerk	6
25	31284-001	Leveling strap LH	1
26	31284-002	Leveling strap RH	1
27	5009	Pin	2
28	5024	Pin	2
29	8121222	Cotter Pin	4
30	8181635	Screw .38-24 x .75	4
31	2037000	4 x 6 x .38 angle	2
32	5504-005	Bushing	12
33	5504-001	Bushing	8
34	5018	Pin	2
35	5017	Pin	2
36	8107-010	Flatwasher 1.00	4
37	5702371	Spring pin	2
38	8120396	Flatwasher .50	4
39	4220240	Insert	4

PLATFORM ASSEMBLY

Item	Part Number	Description	Qty
1	3406	Platform Asm-incl 2 to 6 48	1
1	3453	Platform Asm-incl 2 to 6 60	1
2	31023	Plat. main (48 wide)	1
2	31609	Plat. main (60 wide)	1
3	31024	Platform extension (48 wide)	1
3	31608	Platform extension (60 wide)	1
4	5056	Pin	2
5	5781001	Retaining ring	4
6	31020-002	Platform hinge RH	1
7	31020-001	Platform hinge LH	1
8	8120382	Lockwasher .38	12
9	8108-001	Screw .38-16 x 1.75 SS	12
10	8107-011	Washer .62	2

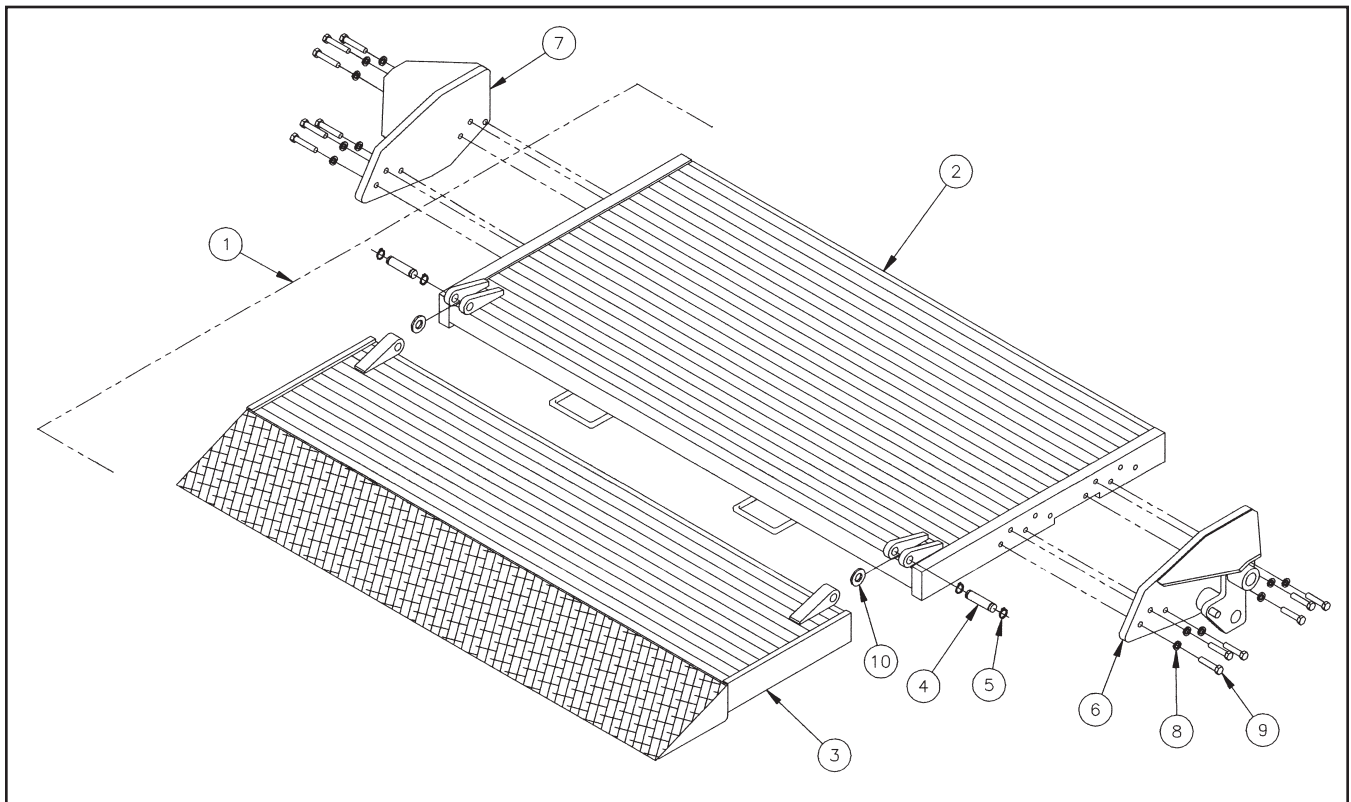

SPRING ASSIST ADJUSTMENT

- Notes:**
1. The platform manual fold/unfold assist spring adjustment is preset at the factory to best cover the entire bed height range of the SL liftgate. However, the spring assist is adjustable to suit the personal tastes of the operator and their particular installed bed height.
 2. Adjusting the spring assist so the platform is easier to fold, may make the liftgate harder to unfold because the spring will start stretching earlier. Also, when the platform is folded back into the stored position the spring may start to pull the operator toward the truck more than they would like. The spring should be adjusted to give the best balance between ease of folding and ease of unfolding.
 3. The liftgate should be folded and unfolded as close to the ground as is comfortable because this is where the spring assist is the greatest and is where it takes the least amount to fold. It is also easier to unfold in this position with the liftarm lowered, because the mechanism brings the platform closer to falling over center.
 4. After spring adjustments have been made, make sure that when the liftgate is unfolded and on the ground, the spring's extended length does not exceed the 21.00 inch maximum when measured from the inside of one looped end to the other on the spring itself as shown below.
 5. The SL liftgate ships with what is labeled below as the standard setup. The standard setup uses 4 chain links between the quick link and the spring link weld and the chain links are bolted to hole 1 on the spring link weld. This is the second strongest setting for the spring assist, which makes it easier to fold. The only way to add more assist is to use three chain links (let one link dangle as shown) and bolt the chain links to hole 4 on the springlink weld. To lessen the spring assist, which will make the liftgate easier to unfold but harder to fold, simply use all four chain links from the standard setup and bolt the chain links to hole 2, 3 or 4 on the spring link weld. Use steps below for making spring adjustments.

Step 1 With the liftgates safety stow chains connected but as loose as possible, lower the liftgate out of the stored position just enough so that the retaining rings can be removed from the 1.00 dia. pins on the liftarm, which the spring link welds are slid over. Do not power the liftgate down once the stow chains are tight. Make sure that there is no tension on the fold assist springs before proceeding.

Step 2 Slide the spring link welds off of the 1.00 dia. pins on the liftarms.

Step 3 Select one of the five spring assist settings shown below by selecting which hole of the spring link weld the chain links are bolted to and whether 3 or 4 chain links are used. Make sure all fasteners are secured tightly once the desired setting is selected.

Step 4 Slide the spring link welds back on to the 1.00 dia. pins on the liftarms and re-install retaining rings.

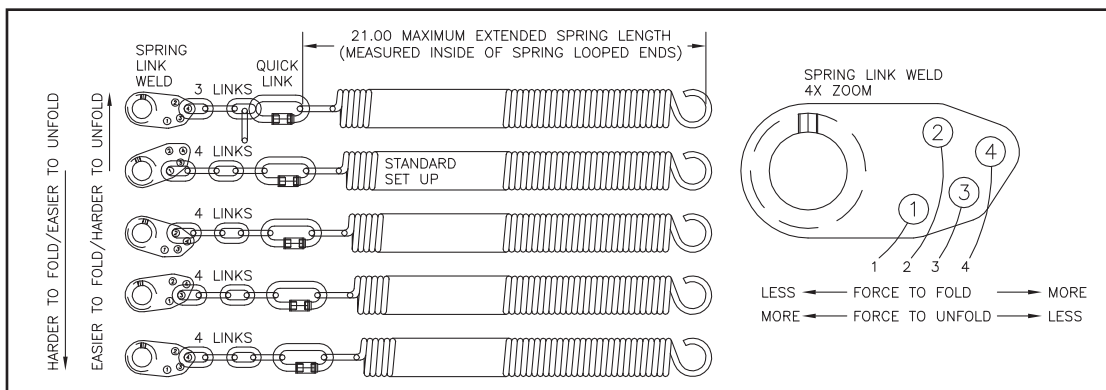

TROUBLESHOOTING GUIDE SL15/20EST

- Test Equipment:**
1. 0-5000 psi pressure gauge
 2. DC voltmeter/ohm meter
 3. DC amp meter
 4. standard mechanics tools

Note: Please refer to the electrical diagrams and hose connection drawings in the liftgate's owners manual when troubleshooting. This guide is only for standard Thieman liftgates. Special liftgates with options other than those in the owner's manual will require special diagrams for troubleshooting. Read and understand this entire guide completely before doing any troubleshooting. Certain listed problems may be related to other problems listed so a comprehensive knowledge is required before proceeding.

1. Problem - Pump motor will not run in the raise or lower mode

- Causes -
- a. Tripped circuit breaker
 - b. Blown 20A fuse
 - c. Defective or undercharged battery(ies)
 - d. Improper battery cable connection or improper ground connection
 - e. Defective or improperly wired raise switch
 - f. Defective or improperly wired lower switch
 - g. Defective or improperly wired solenoid start switch
 - h. Defective pump motor

- Corrections -
- a. Reset the circuit breaker located within 2ft of the liftgate supply battery(ies).
 - b. Replace 20A fuse
 - c. The "at rest" voltage for the batteries without the engine running and under no load should be at least 12.5V. The minimum voltage between the motor stud and ground is 9V at maximum load conditions. If proper voltage is not present, charge or replace the batteries. The battery(ies) on the vehicle should be that which has a minimum 150 amp reserve capacity.
 - d. Trace battery and ground cable connections to locate improper connection(s). Make sure the ground cable is installed going from the aluminum pump base to bare metal on the truck frame. Make sure the ground cable from the batteries to the frame is a heavy 2ga. cable and that it too is connected to bare metal on the frame. Make sure there is 12.5V present at the large terminal on the motor start solenoid where the 2ga. cable from the batteries is connected. Replace any damaged cables and repair any bad connections.
 - e. Check for voltage on the black wire at the control switch. If no voltage is present the black wire from the motor start solenoid is loose or broken and needs repaired. If voltage is present then check for voltage at the green and white wire on the switch with the switch in the "RAISE" position. If no voltage is present, replace the switch.
 - f. If the pump motor runs in the "RAISE" position but will not run in the "DOWN" position, then check for voltage on the white and red wire at the switch. If no voltage is present replace the switch.
 - g. Check for voltage on the white wire at the motor start switch when the switch

is activated. If no voltage exists the white wire is loose or broken between the switch and the motor start solenoid. Check that the purple ground wire on the start solenoid is connected properly and there are no bad connections. If there is voltage on the white wire and the coil does not energize or if there is no voltage present at the motor terminal then replace the start switch.

- h. With the switch activated in the “RAISE” or “LOWER” position and the motor start solenoid is activated, check for voltage at the motor terminal. If voltage is present and the motor is not running, replace the motor.

2. Problem - Liftgate will not raise to bed with a load and the pump motor running

- Causes -
- a. Low hydraulic fluid
 - b. Cylinders are plumbed incorrectly to pump
 - c. Overload condition
 - d. Defective raise solenoid coil or valve
 - e. Improperly adjusted or defective main relief valve
 - f. Lift cylinders are bypassing, liftgate is drifting down
 - g. Broken hydraulic line
 - h. Clogged or disconnected suction line
 - i. Defective pump

- Corrections -
- a. Make sure the reservoir has the proper amount of fluid. Either check for the fluid line through the plastic reservoir or for metal reservoirs remove the breather cap and check the fluid line through the fill hole. The hydraulic fluid should be within 1/2” of the top of the reservoir with the liftgate in the stored position. Fill with Dexron III automatic transmission fluid.
 - b. Check that the cylinders and pump are plumbed together according to the drawings in the liftgates owners manual. The C1 port on the pump (C1 is stamped in the aluminum pump base by this port) is the high pressure port and should connect to the rod end of the cylinders. The other port on the cylinders are the low pressure lowering ports and should be plumbed to the C2 port on the pump (C2 is stamped in the aluminum pump base by this port).
 - c. The power unit on the SL 15/20 is equipped with a lifting relief valve to prevent overloading of the liftgate. The relief setting should be 1850 PSI for the SL15 and 2450 PSI for the SL20.
 - d. With the “RAISE” switch engaged check for voltage on the green wire at the switch. If no voltage is present replace the switch. If voltage is present, with the “RAISE” switch engaged, check for voltage at the green wire on the raise solenoid valve coil terminal at the pump. If no voltage is present, the green wire from the “RAISE” switch is loose or broken and needs repaired. If there is voltage (minimum of 9.5 volts) and the valve is not opening to allow the gate to raise, either the raise coil is bad or the entire raise coil/valve assembly is bad. To check to see if the coil is defective, remove the green wire from the spade terminal on the raise coil and check for continuity between the spade terminal and the nut which holds the coil on the valve stem. If continuity does not exist, replace the defective coil, otherwise replace the defective raise coil/valve assembly.
 - e. See section “c” above for relief valve setting. Plumb a pressure gauge into the high pressure circuit of the liftgate (those hoses connected to the C1 port on

the pump). Remove all loads from the liftgate's platform. Engage the "RAISE" switch until the liftgate is fully raised. Keep the "RAISE" switch engaged until the pump bypasses through the relief valve and note the pressure on the gauge at this time. If the rated relief pressure is not present during relief, adjust the high pressure relief valve setting as necessary. There are two relief valves on this pump so make sure to adjust only the high pressure relief setting at this time. The high pressure relief is the higher one on the aluminum pump base. If the relief pressure is not attainable the relief valve must be cleaned and/or replaced or the pump is defective. See part i below.

- f. If the liftgate will not raise with a load on the platform but empty is raising slowly or only partially, one or both of the cylinders may be bypassing. To check for bypassing cylinders do the following. Lower the gate to the ground to relieve all pressure from the cylinders. Disconnect both cylinders from the liftarm. Press the "RAISE" switch until both cylinders are fully retracted. Disconnect the low pressure hoses from the power unit at the swivel fitting at the C2 port at the pump. Plug the newly opened end(s) of the swivel fitting. Put the loose ends of the disconnected hoses in a container to catch any oil, which comes out during this test. Press the "RAISE" switch for 15 to 20 seconds and watch for a steady stream of fluid coming out of one of the disconnected hose ends into the container. If no steady stream of oil is present reconnect all hoses and press the "LOWER" switch until both cylinders are fully extended. Disconnect the high pressure hoses from the power unit at the swivel fitting at the C1 port at the pump. Plug the newly opened end(s) of the swivel fitting. Put the loose ends of the disconnected hoses in a container to catch any oil, which comes out during this test. Press the "LOWER" switch for 15 to 20 seconds and watch for a steady stream of fluid coming out of one of the disconnected hose ends into the container. Replace or rebuild any cylinder with fluid coming out of its disconnected hose end, as this indicates fluid is bypassing the piston seals on the cylinder. Reconnect rebuilt or replaced cylinders and hoses as before.
- g. Broken or punctured hydraulic lines and fittings must be replaced with care to avoid injury from high pressure oil streams.
- h. With the liftgate at the ground, disconnect the power unit and remove the reservoir. Check to see if the suction tube is clogged or has fallen out of the pump base. Clean the screen or reattach the suction tube as required.
- i. If all else fails replace the power unit, it is probably worn out.

3. Problem - Liftgate will not lower with the pump motor running

- Causes -
- a. Defective lowering solenoid coil or valve
 - b. Clogged or defective hydraulic lines, fittings or flow controls

- Corrections -
- a. With the "LOWER" switch engaged check for voltage on the red wire at the switch. If no voltage is present replace the switch. If voltage is present, with the "LOWER" switch engaged, check for voltage at the red wire on the lower solenoid valve coil terminal. If no voltage is present, the red wire from the "LOWER" switch is loose or broken and needs replaced. If there is voltage (minimum of 9.5 volts) and the valve is not opening to allow the gate to lower, either the lower coil is bad or the entire lower coil/valve assembly is bad. To

check to see if the coil is defective, remove the red wire from the spade terminal on the lower coil and check for continuity between the spade terminal and the nut, which holds the coil on the valve stem. If continuity does not exist, replace the defective coil, otherwise replace the defective lower coil/valve assembly.

- b. Remove any obstruction in the hoses, fittings or flow controls or replace any hose, fitting or flow control, which does not allow fluid to flow through freely.

4. Problem - Liftgate raises slowly - The raise speed of the SL15/20 on a 54" bed height while empty at 70° F is approximately 6-8 seconds. The raise speed loaded for the same conditions is approximately 13-16 seconds.

- Causes -
- a. Overload condition
 - b. Cold weather
 - c. Partially blocked suction screen
 - d. Lift cylinders are bypassing
 - e. Improperly adjusted or defective raise relief valve
 - f. Low voltage and/or bad ground
 - g. Worn out pump

- Corrections -
- a. See section 2c
 - b. Refer to Owner's Manual for alternative oils to use for cold weather conditions.
 - c. Remove reservoir and clean or replace suction screen as necessary.
 - d. See section 2f
 - e. See section 2e
 - f. The minimum voltage between the motor stud and ground is 9.5 volts at maximum load conditions. See section 1b and 1c.
 - g. After all other corrections are performed it will be necessary to replace the pump.

5. Problem - Foamy oil flowing from reservoir breather

- Causes -
- a. Air is present in the system

- Corrections -
- a. This can occur if the motor is not running as the liftgate is lowered. See problem 1, part e and f. Also air can enter the system if the fluid level is low, see problem 2, part a, or if the suction tube is disconnected, see problem 2, part h. Also air may enter through fittings, which are not tightened properly, so check for any leaks around fittings or hoses. Once the source of the air is determined, the cylinders must be bled of all air. Most air can be removed from the system by lowering the gate to the ground to relieve all pressure from the cylinders, unpinning the cylinders and cycling them back and forth several times from fully extended to fully retracted and allowing the pump to bypass through the relief valves for a few seconds in each direction.

If you have any questions or problems that are not covered in this guide please call Thieman's Engineering Department at 1-800-524-5210.

